

Altivar Machine ATV320

Variable Speed Drives for Asynchronous and Synchronous Motors

POWERLINK Manual - VW3A3619

09/2018



The information provided in this documentation contains general descriptions and/or technical characteristics of the performance of the products contained herein. This documentation is not intended as a substitute for and is not to be used for determining suitability or reliability of these products for specific user applications. It is the duty of any such user or integrator to perform the appropriate and complete risk analysis, evaluation and testing of the products with respect to the relevant specific application or use thereof. Neither Schneider Electric nor any of its affiliates or subsidiaries shall be responsible or liable for misuse of the information contained herein. If you have any suggestions for improvements or amendments or have found errors in this publication, please notify us.

You agree not to reproduce, other than for your own personal, noncommercial use, all or part of this document on any medium whatsoever without permission of Schneider Electric, given in writing. You also agree not to establish any hypertext links to this document or its content. Schneider Electric does not grant any right or license for the personal and noncommercial use of the document or its content, except for a non-exclusive license to consult it on an "as is" basis, at your own risk. All other rights are reserved.

All pertinent state, regional, and local safety regulations must be observed when installing and using this product. For reasons of safety and to help ensure compliance with documented system data, only the manufacturer should perform repairs to components.

When devices are used for applications with technical safety requirements, the relevant instructions must be followed.

Failure to use Schneider Electric software or approved software with our hardware products may result in injury, harm, or improper operating results.

Failure to observe this information can result in injury or equipment damage.

© 2018 Schneider Electric. All Rights Reserved.

Table of Contents



	Safety Information	5
	About the Book	9
Chapter 1	POWERLINK Overview	13
	Overview	13
Chapter 2	Hardware Setup	15
	Hardware Presentation	16
	Firmware and Description File	16
	Installation of the Module	17
	Electrical Installation	18
Chapter 3	Software Setup	19
	Configuring the Communication Parameters	20
	[Address] <i>Adr C</i>	21
	[MAC@] <i>MAC</i>	21
	Limitation	21
	IO Scanner	22
Chapter 4	Diagnostics and Troubleshooting	23
	Fieldbus Status LEDs	24
	Diagnostics	26
Glossary	27



Important Information

NOTICE

Read these instructions carefully, and look at the equipment to become familiar with the device before trying to install, operate, service, or maintain it. The following special messages may appear throughout this documentation or on the equipment to warn of potential hazards or to call attention to information that clarifies or simplifies a procedure.



The addition of this symbol to a “Danger” or “Warning” safety label indicates that an electrical hazard exists which will result in personal injury if the instructions are not followed.



This is the safety alert symbol. It is used to alert you to potential personal injury hazards. Obey all safety messages that follow this symbol to avoid possible injury or death.

DANGER

DANGER indicates a hazardous situation which, if not avoided, **will result in** death or serious injury.

WARNING

WARNING indicates a hazardous situation which, if not avoided, **could result in** death or serious injury.

CAUTION

CAUTION indicates a hazardous situation which, if not avoided, **could result in** minor or moderate injury.

NOTICE

NOTICE is used to address practices not related to physical injury.

PLEASE NOTE

Electrical equipment should be installed, operated, serviced, and maintained only by qualified personnel. No responsibility is assumed by Schneider Electric for any consequences arising out of the use of this material.

A qualified person is one who has skills and knowledge related to the construction and operation of electrical equipment and its installation, and has received safety training to recognize and avoid the hazards involved.

Qualification Of Personnel

Only appropriately trained persons who are familiar with and understand the contents of this manual and all other pertinent product documentation are authorized to work on and with this product. In addition, these persons must have received safety training to recognize and avoid hazards involved. These persons must have sufficient technical training, knowledge and experience and be able to foresee and detect potential hazards that may be caused by using the product, by changing the settings and by the mechanical, electrical and electronic equipment of the entire system in which the product is used. All persons working on and with the product must be fully familiar with all applicable standards, directives, and accident prevention regulations when performing such work.

Intended Use

This product is a drive for three-phase synchronous, asynchronous motors and intended for industrial use according to this manual. This product is a safety module, which supports various device safety functions and intended for industrial use according to this manual. The product may only be used in compliance with all applicable safety standard and local regulations and directives, the specified requirements and the technical data. The product must be installed outside the hazardous ATEX zone. Prior to using the product, you must perform a risk assessment in view of the planned application. Based on the results, the appropriate safety measures must be implemented. Since the product is used as a component in an entire system, you must ensure the safety of persons by means of the design of this entire system (for example, machine design). Any use other than the use explicitly permitted is prohibited and can result in hazards.

Product Related Information

Read and understand these instructions before performing any procedure with this drive.

 DANGER
<p>HAZARD OF ELECTRIC SHOCK, EXPLOSION OR ARC FLASH</p> <ul style="list-style-type: none">● Only appropriately trained persons who are familiar with and understand the contents of this manual and all other pertinent product documentation and who have received safety training to recognize and avoid hazards involved are authorized to work on and with this drive system. Installation, adjustment, repair and maintenance must be performed by qualified personnel.● The system integrator is responsible for compliance with all local and national electrical code requirements as well as all other applicable regulations with respect to grounding of all equipment.● Many components of the product, including the printed circuit boards, operate with mains voltage.● Only use properly rated, electrically insulated tools and measuring equipment.● Do not touch unshielded components or terminals with voltage present.● Motors can generate voltage when the shaft is rotated. Prior to performing any type of work on the drive system, block the motor shaft to prevent rotation.● AC voltage can couple voltage to unused conductors in the motor cable. Insulate both ends of unused conductors of the motor cable.● Do not short across the DC bus terminals or the DC bus capacitors or the braking resistor terminals.● Before performing work on the drive system:<ul style="list-style-type: none">○ Disconnect all power, including external control power that may be present. Take into account that the circuit breaker or main switch does not de-energize all circuits.○ Place a Do Not Turn On label on all power switches related to the drive system.○ Lock all power switches in the open position.○ Wait 15 minutes to allow the DC bus capacitors to discharge.○ Follow the instructions given in the chapter "Verifying the Absence of Voltage" in the installation manual of the product.● Before applying voltage to the drive system:<ul style="list-style-type: none">○ Verify that the work has been completed and that the entire installation cannot cause hazards.○ If the mains input terminals and the motor output terminals have been grounded and short-circuited, remove the ground and the short circuits on the mains input terminals and the motor output terminals.○ Verify proper grounding of all equipment.○ Verify that all protective equipment such as covers, doors, grids is installed and/or closed. <p>Failure to follow these instructions will result in death or serious injury.</p>

Drive systems may perform unexpected movements because of incorrect wiring, incorrect settings, incorrect data or other errors.

 WARNING
<p>UNANTICIPATED EQUIPMENT OPERATION</p> <ul style="list-style-type: none">● Carefully install the wiring in accordance with the EMC requirements.● Do not operate the product with unknown or unsuitable settings or data.● Perform a comprehensive commissioning test. <p>Failure to follow these instructions can result in death, serious injury, or equipment damage.</p>

Damaged products or accessories may cause electric shock or unanticipated equipment operation.

DANGER

ELECTRIC SHOCK OR UNANTICIPATED EQUIPMENT OPERATION

Do not use damaged products or accessories.

Failure to follow these instructions will result in death or serious injury.

Contact your local Schneider Electric sales office if you detect any damage whatsoever.

WARNING

LOSS OF CONTROL

- The designer of any control scheme must consider the potential failure modes of control paths and, for critical control functions, provide a means to achieve a safe state during and after a path failure. Examples of critical control functions are emergency stop, overtravel stop, power outage and restart.
- Separate or redundant control paths must be provided for critical control functions.
- System control paths may include communication links. Consideration must be given to the implications of unanticipated transmission delays or failures of the link.
- Observe all accident prevention regulations and local safety guidelines (1).
- Each implementation of the product must be individually and thoroughly tested for proper operation before being placed into service.

Failure to follow these instructions can result in death, serious injury, or equipment damage.

(1) For USA: Additional information, refer to NEMA ICS 1.1 (latest edition), Safety Guidelines for the Application, Installation, and Maintenance of Solid State Control and to NEMA ICS 7.1 (latest edition), Safety Standards for Construction and Guide for Selection, Installation and Operation of Adjustable-Speed Drive Systems.

NOTICE

DESTRUCTION DUE TO INCORRECT MAINS VOLTAGE

Before switching on and configuring the product, verify that it is approved for the mains voltage.

Failure to follow these instructions can result in equipment damage.

The temperature of the products described in this manual may exceed 80 °C (176 °F) during operation.

WARNING

HOT SURFACES

- Ensure that any contact with hot surfaces is avoided.
- Do not allow flammable or heat-sensitive parts in the immediate vicinity of hot surfaces.
- Verify that the product has sufficiently cooled down before handling it.
- Verify that the heat dissipation is sufficient by performing a test run under maximum load conditions.

Failure to follow these instructions can result in death, serious injury, or equipment damage.

This equipment has been designed to operate outside of any hazardous location. Only install this equipment in zones known to be free of a hazardous atmosphere.

DANGER

POTENTIAL FOR EXPLOSION

Install and use this equipment in non-hazardous locations only.

Failure to follow these instructions will result in death or serious injury.

Machines, controllers, and related equipment are usually integrated into networks. Unauthorized persons and malware may gain access to the machine as well as to other devices on the network/fieldbus of the machine and connected networks via insufficiently secure access to software and networks.

 WARNING

UNAUTHORIZED ACCESS TO THE MACHINE VIA SOFTWARE AND NETWORKS

- In your hazard and risk analysis, consider all hazards that result from access to and operation on the network/fieldbus and develop an appropriate cyber security concept.
- Verify that the hardware infrastructure and the software infrastructure into which the machine is integrated as well as all organizational measures and rules covering access to this infrastructure consider the results of the hazard and risk analysis and are implemented according to best practices and standards covering IT security and cyber security (such as: ISO/IEC 27000 series, Common Criteria for Information Technology Security Evaluation, ISO/ IEC 15408, IEC 62351, ISA/IEC 62443, NIST Cybersecurity Framework, Information Security Forum - Standard of Good Practice for Information Security).
- Verify the effectiveness of your IT security and cyber security systems using appropriate, proven methods.

Failure to follow these instructions can result in death, serious injury, or equipment damage.

 WARNING

LOSS OF CONTROL

Perform a comprehensive commissioning test to verify that communication monitoring properly detects communication interruptions

Failure to follow these instructions can result in death, serious injury, or equipment damage.



At a Glance

Document Scope

The purpose of this document is to:

- show you how to install the POWERLINK module on your drive.
- show you how to configure the drive to use POWERLINK fieldbus.

NOTE: Read and understand this document and all related documents (see below) before installing, operating, or maintaining your drive.

Validity Note

Original instructions and information given in this manual have been written in English (before optional translation).

This documentation is valid for the Altivar Machine drives.

The technical characteristics of the devices described in the present document also appear online. To access the information online:

Step	Action
1	Go to the Schneider Electric home page www.schneider-electric.com .
2	In the Search box type the reference of a product or the name of a product range. <ul style="list-style-type: none">• Do not include blank spaces in the reference or product range.• To get information on grouping similar modules, use asterisks (*).
3	If you entered a reference, go to the Product Datasheets search results and click on the reference that interests you. If you entered the name of a product range, go to the Product Ranges search results and click on the product range that interests you.
4	If more than one reference appears in the Products search results, click on the reference that interests you.
5	Depending on the size of your screen, you may need to scroll down to see the data sheet.
6	To save or print a data sheet as a .pdf file, click Download XXX product datasheet .

The characteristics that are presented in the present document should be the same as those characteristics that appear online. In line with our policy of constant improvement, we may revise content over time to improve clarity and accuracy. If you see a difference between the document and online information, use the online information as your reference.

Related Documents

Use your tablet or your PC to quickly access detailed and comprehensive information on all our products on www.schneider-electric.com.

The internet site provides the information you need for products and solutions:

- The whole catalog for detailed characteristics and selection guides,
- The CAD files to help design your installation, available in over 20 different file formats,
- All software and firmware to maintain your installation up to date,
- A large quantity of White Papers, Environment documents, Application solutions, Specifications... to gain a better understanding of our electrical systems and equipment or automation,
- And finally all the User Guides related to your drive, listed below:

(Other option manuals and Instruction sheets are available on www.schneider-electric.com)

Title of Documentation	Reference Number
ATV320 Catalog	DIA2ED2160311EN (English), DIA2ED2160311FR (French)
ATV320 Getting Started	NVE21763 (English), NVE21771 (French), NVE21772 (German), NVE21773 (Spanish), NVE21774 (Italian), NVE21776 (Chinese)
ATV320 Getting Started Annex (SCCR)	NVE21777 (English)
ATV320 Installation manual	NVE41289 (English), NVE41290 (French), NVE41291 (German), NVE41292 (Spanish), NVE41293 (Italian), NVE41294 (Chinese)
ATV320 Programming manual	NVE41295 (English), NVE41296 (French), NVE41297 (German), NVE41298 (Spanish), NVE41299 (Italian), NVE41300 (Chinese)
ATV320 Modbus Serial Link manual (embedded)	NVE41308 (English)
ATV320 Modbus TCP - Ethernet IP manual (VW3A3616)	NVE41313 (English)
ATV320 PROFIBUS DP manual (VW3A3607)	NVE41310 (English)
ATV320 DeviceNet manual (VW3A3609)	NVE41314 (English)
ATV320 CANopen manual (VW3A3608, 618, 628)	NVE41309 (English)
ATV320 POWERLINK manual (VW3A3619)	NVE41312 (English)
ATV320 EtherCAT manual (VW3A3601)	NVE41315 (English)
ATV320 Communication Parameters	NVE41316 (English)
ATV320 Safety Functions manual	NVE50467 (English), NVE50468 (French), NVE50469 (German), NVE50470 (Spanish), NVE50472 (Italian), NVE50473 (Chinese)
BMP Synchronous Motor manual	0198441113981-EN (English), 0198441113982-FR (French), 0198441113980-DE (German), 0198441113984-ES (Spanish), 0198441113983-IT (Italian), 0198441113985-ZH (Chinese)
ATV320 ATV Logic manual	NVE71954 (English), NVE71955 (French), NVE71957 (German), NVE71959 (Spanish), NVE71958 (Italian), NVE71960 (Chinese)
SoMove: FDT	SoMove_FDT (English, French, German, Spanish, Italian, Chinese)
ATV320: DTM	ATV320_DTM_Library (English, French, German, Spanish, Italian, Chinese)

You can download these technical publications and other technical information from our website at www.schneider-electric.com/en/download

Terminology

The technical terms, terminology, and the corresponding descriptions in this manual normally use the terms or definitions in the relevant standards.

In the area of drive systems this includes, but is not limited to, terms such as **error, error message, failure, fault, fault reset, protection, safe state, safety function, warning, warning message**, and so on.

Among others, these standards include:

- IEC 61800 series: Adjustable speed electrical power drive systems
- IEC 61508 Ed.2 series: Functional safety of electrical/electronic/programmable electronic safety-related
- EN 954-1 Safety of machinery - Safety related parts of control systems
- ISO 13849-1 & 2 Safety of machinery - Safety related parts of control systems
- IEC 61158 series: Industrial communication networks - Fieldbus specifications
- IEC 61784 series: Industrial communication networks - Profiles
- IEC 60204-1: Safety of machinery - Electrical equipment of machines – Part 1: General requirements

In addition, the term **zone of operation** is used in conjunction with the description of specific hazards, and is defined as it is for a **hazard zone** or **danger zone** in the EC Machinery Directive (2006/42/EC) and in ISO 12100-1.

Also see the glossary at the end of this manual.

Contact Us

Select your country on:

www.schneider-electric.com/contact

Schneider Electric Industries SAS

Head Office

35, rue Joseph Monier

92500 Rueil-Malmaison

France

Chapter 1

POWERLINK Overview

Overview

Description

The **VW3A3619** fieldbus module enables the integration of an Altivar variable speed drive into an Ethernet POWERLINK fieldbus system specification V2.



Software and Protocols Supported

The **VW3A3619** POWERLINK module is compliant from the version (V2.7) of ATV320 drive .
If this requirement is not respected, a **[Internal Error] 1 n F 5** error is triggered.

Chapter 2

Hardware Setup

What Is in This Chapter?

This chapter contains the following topics:

Topic	Page
Hardware Presentation	16
Firmware and Description File	16
Installation of the Module	17
Electrical Installation	18

Hardware Presentation

POWERLINK Fieldbus Module

The following figure shows the **VW3A3619** POWERLINK module with 2 RJ45 connectors.

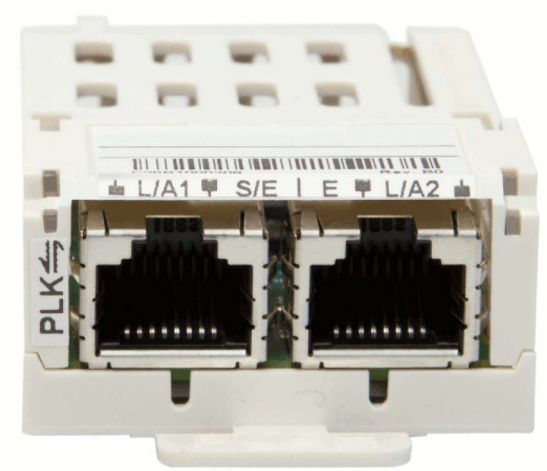

Firmware and Description File

Downloading the XDD File

The associated XDD file is named as the following example:

0800005A_ATV32XXXXXX.xdd

The files are available on www.schneider-electric.com.

Installation of the Module

Before Starting

Check that the module catalog number marked on the label is the same as that on the delivery note corresponding to the purchase order.

Remove the fieldbus module from its packaging and check that it has not been damaged in transit.

Insertion of the Fieldbus Module

The table provides the procedure for insertion of the POWERLINK option module in the drive:

Step	Action
1	Ensure that the power is off.
2	Locate the fieldbus module slot (A).
3	Insert the module.
4	Check that the module is correctly inserted and locked mechanically in the drive.

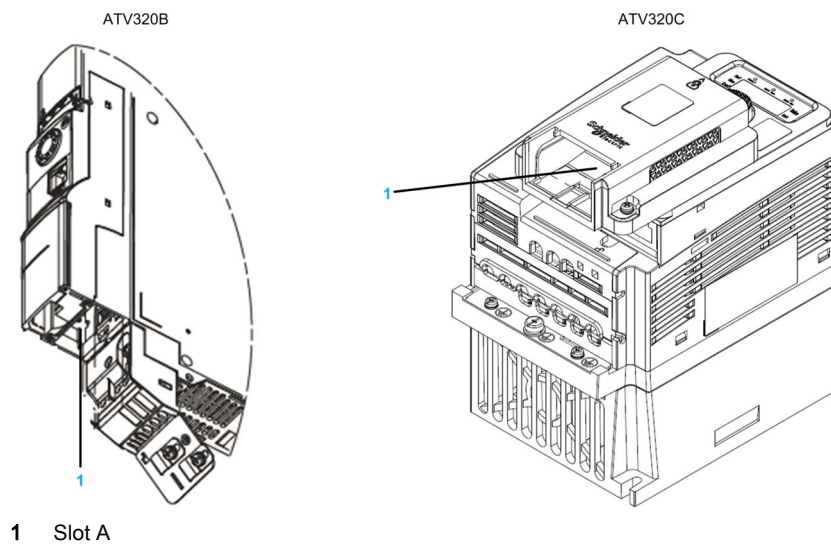

Removal of the Fieldbus Module

The table provides the procedure for removal of the POWERLINK option module from the drive:

Step	Action
1	Ensure that the power is off.
2	Press the strip.
3	Remove the module while maintaining the strip pressed,

Electrical Installation

Pin Layout of the VW3A3619

The **VW3A3619** option module is equipped with 2 RJ45 female sockets for the POWERLINK connection. The following table describes the pin out of the **VW3A3619** RJ45 connector.

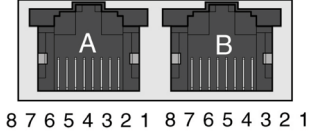
Interface	Pin Assignments		
	PIN	Ethernet	
Application interface POWERLINK  Part A / Port B	1	RxD	Receive Data
	2	RxD\	Receive Data\
	3	TxD	Transmit Data
	4	Termination	–
	5	Termination	–
	6	TxD\	Transmit Data\
	7	Termination	–
	8	Termination	–

Cable Specifications

- Connection accessories may be ordered separately (consult our catalog).
- Use the Schneider Electric cable with two pairs of shielded twisted conductors (reference: TSXCSA100, TSXCSA200, TSXCSA500).
- Keep the Modbus cable separated from the power cables (30 cm (11.8 in.) minimum).
- Make any crossovers of fieldbus cable and the power cables at right-angles, if necessary.

For more information, refer to the TSX DG KBL E manual: “Electromagnetic compatibility of industrial networks and fieldbuses”.

Chapter 3

Software Setup

What Is in This Chapter?

This chapter contains the following topics:

Topic	Page
Configuring the Communication Parameters	20
[Address] <i>ADR</i>	21
[MAC@] <i>MAC</i>	21
Limitation	21
IO Scanner	22

Configuring the Communication Parameters

Overview

The parameters described in this chapter are accessible with the Graphic Display Terminal or with SoMove software. The parameters are visible only if a POWERLINK module is plugged in the drive

Access

The configuration of the POWERLINK communication functions on the Altivar 320 is reachable with the drive menu;

[1.3 CONFIGURATION] (C o n F) → [FULL] (F u L L) → [COMMUNICATION] (C o m -) → [COMMUNICATION CARD] (C b d -).

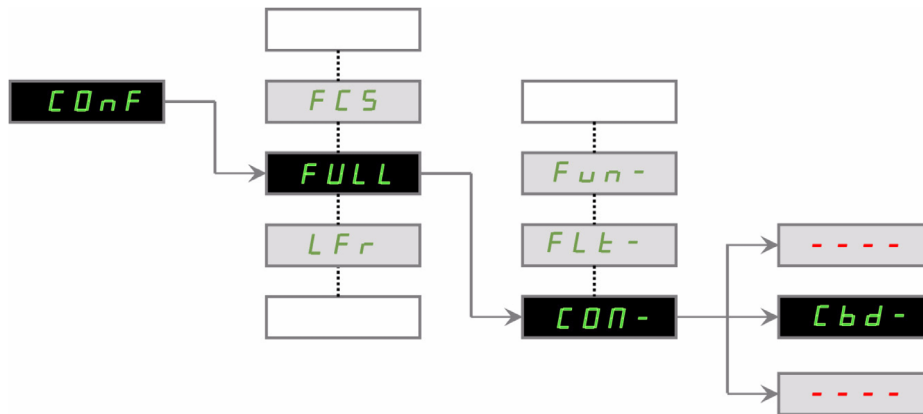

[Address] P d r C

About This Parameter

This parameter defines the address of the drive on the network.

Access

This is a read/write parameter.

This parameter can only be modified when the motor is stopped and the drive is stopped.

The parameter number is 6601.

Possible Settings

The table presents the parameter settings:

Settings	Code	Value	Description
[0 to 239]	0...239	0...239	POWERLINK address of the drive. Factory Settings: 0

[MAC@] P d r C

About This Parameter

This parameter displays the MAC address of the device.

Access

This is a read-only parameter.

The parameter number is 64267, 64268 and 64269.

Possible Settings

The table presents the parameter settings:

Settings	Code	Value	Description
[00-80-F4-XX-XX-XX]	00-80-F4-XX-XX-XX	00-80-F4-XX-XX-XX	MAC address of the port. Left port MAC address is +1 Right port MAC address is +2 Factory Settings: 0

Limitation

Minimum Time Cycle

The minimum time cycle to use POWERLINK fieldbus is 2 ms, otherwise the drive triggers a *C n F* error.

IO Scanner

Configuration I/O Scanning

The I/O scanning service is used to exchange periodic I/O data between:

- A controller or PLC (I/O scanner)
- Devices (I/O scanning servers)

I/O Scanner Setting

The communication scanner is accessible via the following menus: **[COMMUNICATION]** (**C o m -**) and **[COMMUNICATION CARD]** (**C b d -**) submenus.

They are four output variables and four input variables available.

Chapter 4

Diagnostics and Troubleshooting

What Is in This Chapter?

This chapter contains the following topics:

Topic	Page
Fieldbus Status LEDs	24
Diagnostics	26

Fieldbus Status LEDs

LED Indicators



LED Description

Figure	LED	Color	Status	Description
1	L/A1	Green	On	A link to the remote station has been established.
			Blinking	A link to the remote station 1 has been established. The LED blinks when Ethernet activity is present on the bus.
2	S/E	Green / red	–	Status/Error LED. See Status (see below) in the next table.
3	E	Green / red	On	Used to indicate an internal error between the drive and the communication module.
4	L/A2	Green	On	A link to the remote station has been established.
			Blinking	A link to the remote station 2 has been established. The LED blinks when Ethernet activity is present on the bus.
The status/Error LED is green/red dual LED				

Status/Error LEDs Description

The status/error LED is a green/red dual LED. The color green (status) is superimposed on the color red (detected error).

Color	Figure	Description
-	On	<p>The POWERLINK interface has detected an error (incorrect Ethernet frames, increased number of collisions on the network, etc.). If an error is detected in the following states, then the green LED blinks over the red LED:</p> <ul style="list-style-type: none"> ● BASIC_ETHERNET ● PRE_OPERATIONAL_1 ● PRE_OPERATIONAL_2 ● READY_TO_OPERATE <p>1 Status Green 2 Error Red 3 LED S/E</p>
Green	OFF NOT_ACTIVE	The bus is monitored for POWERLINK frames. If a frame is not received within the configured time window (timeout), the drive switches directly into BASIC_ETHERNET status (flickering). If, however, POWERLINK communication is detected during this time, the control node switches directly into the PRE_OPERATIONAL_1 status (single flash).
	Flickering green (approx. 10 Hz) BASIC_ETHERNET	The drive is in BASIC_ETHERNET status, and is operated purely as an Ethernet TCP/IP device. If POWERLINK communication is detected while in this status, the control node switches into the PRE_OPERATIONAL_1 state (single flash). A red LED activated in this state indicates a communication error.
	Single flash (approx. 1 Hz) PRE_OPERATIONAL_1	The drive status is PRE_OPERATIONAL_1. The control node waits until it receives an SoC frame and then switches to PRE_OPERATIONAL_2 status (double flash). A red LED activated in this state indicates a communication error.
	Double flash (approx. 1 Hz) PRE_OPERATIONAL_2	The drive status is PRE_OPERATIONAL_2. In this status, the control node is normally configured by the network manager. After this, a command switches the status to READY_TO_OPERATE (triple flash). A red LED activated in this state indicates a communication error.
	Triple flash (approx. 1 Hz) READY_TO_OPERATE	The drive status is READY_TO_OPERATE. The configuration of the control node is complete. Normal cyclic and asynchronous communication. The PDO data sent corresponds to the PDO mapping used. However, cyclic data is not yet evaluated. A red LED activated in this state indicates a communication error.
	On - OPERATIONAL	The drive status is OPERATIONAL.
	Blinking (approx. 2.5 Hz) STOPPED	The drive status is STOPPED. No output data is produced and no input data is received. Only the appropriate command from the network manager can enter or leave this state.
Red	Red pulses with following on time in ms: 600-150-150-150	Bus Error - Internal interface error.
	Red pulses with following on time in ms: 150-600-600-600	Invalid node number configured in the POWERLINK Node ID parameter in drive HMI.
	Off	No error detected.

System Interruption Indication

Incorrect configuration or hardware can trigger an error. The detected error is displayed via the red error LED using four switch-on phases. The switch-on phases are either 150 ms or 600 ms long. Error code outputs are repeated cyclically after 2 seconds.

Description	Code Display by the Red Status LED									
	X	X	X	-	Brake	X	X	X	-	Brake
RAM error	X	X	X	-	Brake	X	X	X	-	Brake
Bus error	-	X	X	X	Brake	-	X	X	X	Brake
Invalid POWERLINK station number has been configured	X	-	-	-	Brake	X	-	-	-	Brake

Legend:

- X...150 ms
- -...600 ms
- Brake...2 s delay

Diagnostics

Diagnostics Menu

The menu **[DIAGNOSTIC]** (*d G E -*) can only be accessed with the Graphic Display Terminal. It displays detected errors and their cause in plain text and can be used to carry out tests, refer to the programming manual of the drive.

Error Code

Errors that can be cleared with the automatic restart function after the cause has been removed. These errors can also be cleared by applying power ON/OFF cycle or with a digital input or control bit (**[Fault reset]** (*r 5 F*)), refer to the Programming Manual.

Cause and Remedy

Error Code	Name	Probable Cause	Remedy
<i>C n F</i>	[Com. network]	Communication interruption on the fieldbus module.	<ul style="list-style-type: none"> ● Check the environment (electromagnetic compatibility) ● Check the wiring ● Check the time-out ● Replace the fieldbus module ● Contact Schneider Electric Product Support
<i>i L F</i>	[internal com. link]	Communication interruption between the fieldbus module and the drive.	<ul style="list-style-type: none"> ● Check the environment (electromagnetic compatibility) ● Check the connections ● Replace the fieldbus module ● Contact Schneider Electric Product Support

Error Code Description

Error Code	Name	Description	Possible Values
<i>C n F</i>	[Com. network]	<p>This parameter indicates that a communication interruption has been detected. A value is stored depending on the interruption type. This detected error requires a power reset to be cleared.</p> <p>NOTE: <i>(C n F)</i> is available if the drive is:</p> <ul style="list-style-type: none"> ● in "operational" state and if the motor is running, or ● in Ready State (<i>r d Y</i>). 	0: No communication interruption 1: Unspecified interruption 17: lost of link (two ports) 23: invalid Sync Manager configuration 25: No valid outputs 27: Sync Manager watchdog (one port) 29: invalid Sync Manager out configuration 30: invalid Sync Manager in configuration 31: invalid watchdog configuration 36: invalid input mapping 37: invalid output mapping 38: inconsistent settings 43: No valid inputs and outputs 44: Sync error 80: EE no access 81: EE error 96: 0x60
<i>i L F</i>	[internal com. link]	This parameter indicates an internal error. This detected error requires a power reset to be cleared.	18: Interface connection timeout 19: EEPROM/NVS error 21: "No memory" or "background watchdog" or "IOC scanner error"

Tips

- If the display is not active, verify the power supply of the drive.
- If the channel for the reference value or command is assigned to fieldbus, the drive displays **[Freewheel]** *n 5 E* at the power-on until a command or a reference value is written.



A

Abbreviations

Req. = Required

Opt. = Optional

AT

Acknowledge Telegram. This is a telegram sent by the slaves to the master.

C

CAN

Controller Area Network is an internally standardized serial bus system

COB

Communication Object. A unit of transportation in a CAN network. Data must be sent across a CAN Network inside a COB. There are 2048 different COB's in a CAN network. A COB can contain at most 8 bytes of data.

COB ID

Each COB is uniquely identified in a CAN network by a number called the COB Identifier (COB-ID).

CPx

CP0 up to CP4: Sercos III Communication phases

D

DP

Decentralized Periphery

DPWS

Device Profile for Web Service

E

Error

Discrepancy between a detected (computed, measured, or signaled) value or condition and the specified or theoretically correct value or condition.

ESM

EtherCAT State Machine

F

Factory setting

Default configuration of the product.

Fault

Fault is an operating state. If the monitoring functions detect an error, a transition to this operating state is triggered, depending on the error class. A "Fault reset" is required to exit this operating state after the cause of the detected error has been removed. Further information can be found in the pertinent standards such as IEC 61800-7, ODVA Common Industrial Protocol (CIP).

Fault Reset

A function used to restore the drive to an operational state after a detected error is cleared by removing the cause of the error so that the error is no longer active.

I**IDN**

Identification number

L**LSB**

Least Significant Byte

M**MDT**

Master Data Telegram. This is a telegram sent by the master to transmit data to the slaves.

MEI

Modbus Encapsulated Interface

Monitoring function

Monitoring functions acquire a value continuously or cyclically (for example, by measuring) in order to check whether it is within permissible limits. Monitoring functions are used for error detection.

MS0, MS1

Number of a master in the network.

MSB

Most Significant Byte

MST

Master Synchronization Telegram. This is a telegram broadcast by the master to synchronize the timing cycle.

N**NMT**

Network Management. One of the service elements of the application layer in the CAN Reference Model. The NMT serves to configure, initialize, and handle detected errors in a CAN network.

O**OVDA**

Open DeviceNet Vendor Association

P**Parameter**

Device data and values that can be read and set (to a certain extent) by the user.

PDO

Process Data Object

PELV

Protective Extra Low Voltage, low voltage with isolation. For more information: IEC 60364-4-41

PLC

Programmable logic controller

PNO

PROFIBUS Nutzerorganisation e.V. (PROFIBUS User organization).

Power stage

The power stage controls the motor. The power stage generates current for controlling the motor.

Q**QoS**

Quality of Service

Quick Stop

The quick Stop function can be used for fast deceleration of a movement as a response to a detected error or via a command.

R**R/W**

Read and write (write only possible when the drive is not in RUN mode). It is not possible to write these parameters in "5-Operation enabled" or "6-Quick stop active" states. If the parameter is written in the "4-Switched on" state, transition to "2-Switch on disabled" is activated.

RPDO

Receive PDO

S**SNMP**

Simple Network Management Protocol

SNTP

Simple Network Time Protocol

SYNC

Synchronization Object

T**TPDO**

Transmit PDO

V**VSD**

Variable Speed Drive

W**Warning**

If the term is used outside the context of safety instructions, a warning alerts to a potential problem that was detected by a monitoring function. A warning does not cause a transition of the operating state.

Z**Zone of operation**

This term is used in conjunction with the description of specific hazards, and is defined as it is for a **hazard zone** or **danger zone** in the EC Machinery Directive (2006/42/EC) and in ISO 12100-1.

