

Oil Conditioning Unit (OCU)

Off-line filtration for the removal of water or particulate from hydraulic and lube system fluids.



A cost-effective solution that helps ensure system reliability.

The Parker Oil Conditioning Units (OCU) are a family of off-line filtration packages designed to effectively remove water or particulate contamination from hydraulic and lube system fluids. The high performance, high capacity design enables the efficient removal of the very fine contaminants that cause premature wear in expensive hydraulic components. In addition, the precursors to varnish are also reduced or eliminated completely.

The compact, user-friendly OCUs are a cost effective method of reducing system contamination while helping to ensure the reliability of your hydraulic or lube system.



Contact Information:

Parker Hannifin
Hydraulic Filter Division Europe

European Product
Information Centre
Freephone: 00800 27 27 5374
(from AT, BE, CH, CZ, DE, EE, ES,
FI, FR, IE, IT, PT, SE, SK, UK)
filtrationinfo@parker.com

www.parker.com/hfde



Product Applications:

- **Aviation**
 - ground support equipment
 - simulators
- **Power Generation**
 - steam and gas turbine hydraulic and lubrication
- **Automotive**
 - presses
 - stamping equipment
- **Steel Mills**
 - rolling mills
 - continuous casters
 - sheet mills
- **Injection Moulding**
 - hydraulic circuits
- **Railway**
 - car assembly
 - wheel presses
- **Pulp & Paper**
 - machine lubrication
- **Construction**
 - timber harvesting
 - aerial lifts
 - excavators
- **Wind Power**
 - turbine generators
 - gearboxes
- **Oil & Gas**
 - hydraulic equipment

Parker Hannifin
Hydraulic Filter Division Europe
FDHB814UK

Technology

Oil Conditioning Unit

The filter design allows the oil to flow under pressure through 114mm of engineered media with three distinct stages of filtration and water absorption.

The largest particles are retained in the top of the element (1), making for an excellent diagnostic tool. Smaller particles are trapped in the mid stage (2), and the smallest particles are trapped in the lower and most compressed part of the element (3).

The cellulose media allows water absorption of up to 200 millilitres within the filter, reducing the water concentration in oil to less than 100 parts per million.

Equally noteworthy is the efficiency of the media in removing resins, metals and oxidation products, all of which are extremely damaging to close-tolerance components.

Manufactured from a specifically engineered cellulose material wound onto a central core, the OCU combines filtration principles to achieve effective filtration – low flow, low pressure and depth loading axial filtration – flow direction from the top to the bottom.



A card sleeve compresses the lower part of the element to increase the density and a non-woven cloth protects the base and stops particle migration.

Features and Benefits

- Solid Partical Filtration
- Water Absorption
- Sludge, Resin, and Oxidation Absorption

The Parker OCU Benefits

- Removing up to 99% of all Solid Contaminates typically
- Reducing the Water Concentration to Less than 100 ppm typically
- Eliminating Resins and Oxidation Products
- Longer Life for Hydraulic Components

- Significant Reduction of Oil Consumption and Oil Disposal Cost
- Low Cost Full Flow Filter Cartridges
- Reduce Equipment Downtime
- Reduce Operating Cost
- Increase Profit

Features and Benefits Continued



Tool-less access and easy service via the T-handle.

The combination of chemically treated cellulose and synthetic layers of media presents a massive surface area to remove solid contamination and emulsified water. The result is both exceptional dirt holding capacity and removal of water concentration to less than 100 ppm.

The engineered base design at the bottom of the housing supports the element under high pressure and provides a channelled migration path for clean fluid to flow back into the primary stream.

The Oil Conditioning Unit is designed as a top load filter, but can be mounted at any angle using the heavy-duty mounting bracket.



The intricately channelled base provides a large footprint to fully support the element under pressure, ensuring uniform loading of the element. Ultra-clean oil flows through the channels into the clean oil stream.

Element Performance

Model OC1				
Media Grade	Part Number	Capacity @ 1.7 bar (25 PSID)	Capacity @ 3.5 bar (50 PSID)	Efficiency
2 Micron	942650	16.2 grams	23.3 grams	B2>400
10 Micron	942652	28 grams	44.3 grams	B10>400

Model OC2				
Media Grade	Part Number	Capacity @ 1.7 bar (25 PSID)	Capacity @ 3.5 bar (50 PSID)	Efficiency
2 Micron	942654	22 grams	45.8 grams	B2>400
10 Micron	942656	36.5 grams	61.6 grams	B10>400
Water absorption for the OC2 element (part number 942682) is typically 900 cc.				

Results typical from Multipass tests run per modified test standard ISO 16889 to 3.5 bar (50 PSID) terminal - 100 mg/L BUGL ISO Medium Test Dust was used as per the standard - User results will vary based on system particle distribution.

Dirt Holding Capacity results will typically improve with soft or sub-micron size particles due to reduced surface 'caking'.

OC1 without Pump/Motor

Specifications

Specifications	OC1
Maximum fitter housing pressure	12.4 bar (180 PSI)
Maximum system pressure	245 bar (3552 PSI)
Port Size (inlet/outlet)	SAE 6/SAE 6
Dimensions	W162 x D166 x H317 mm (W6.38 x D6.54 x H12.48 in.)
Weight	4.5 kg (10 lbs)
Flow Rate	1.5 L/min. (0.4 GPM)

The Parker OCU filter is supplied including:

- Flow / pressure control valve
- Bypass valve

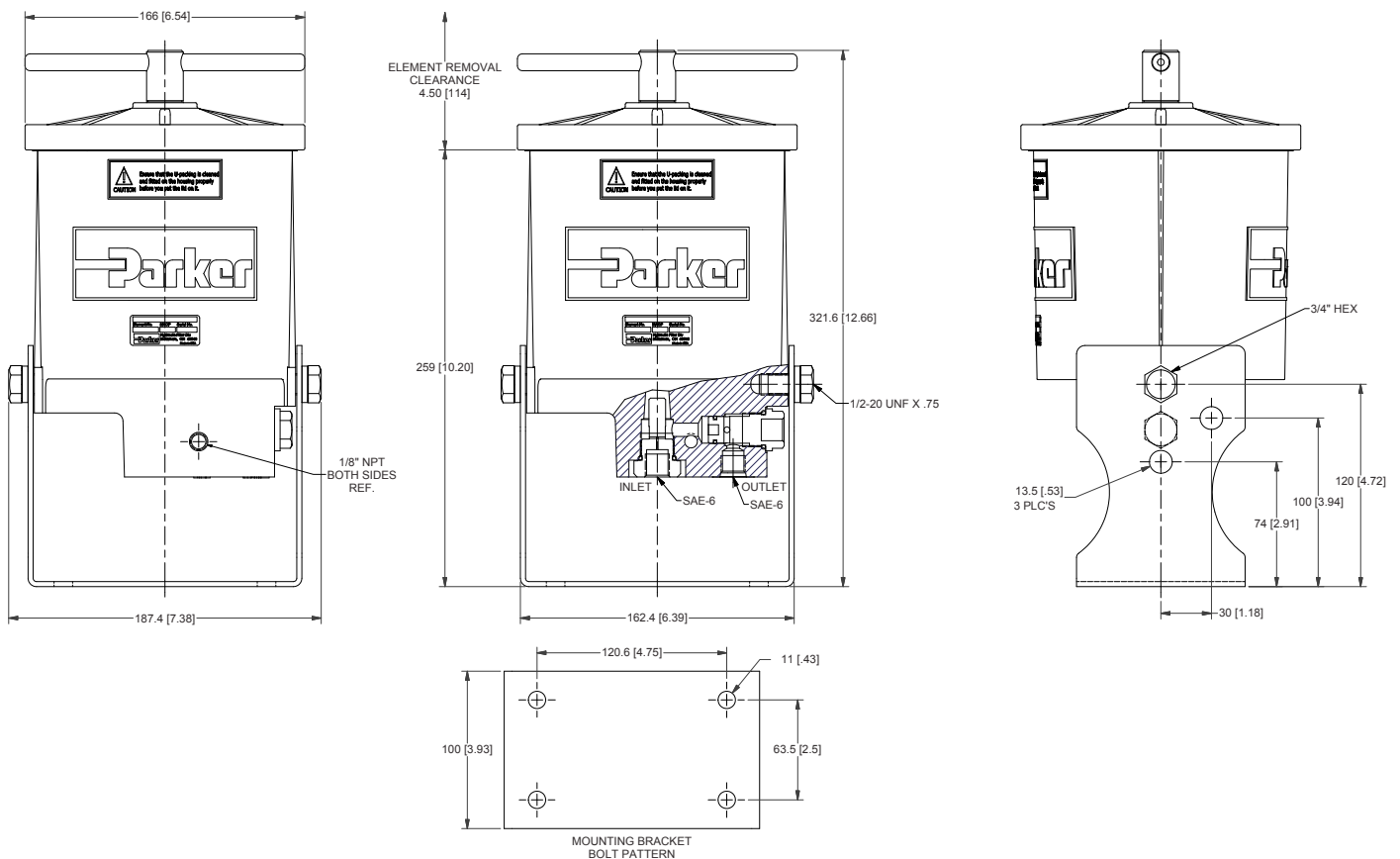

* Dimensions in mm (inch)

OC2 without Pump/Motor

Specifications

Specifications	OC2
Maximum fitter housing pressure	12.4 bar (180 PSI)
Maximum system pressure	245 bar (3552 PSI)
Port Size (inlet/outlet)	SAE 6/SAE 8
Dimensions	W204 x D206 x H321 mm (W8.03 x D8.11 x H12.64 in)
Weight	6.8 kg. (15 lbs)
Flow Rate	2 L/min. (0.5 GPM)

The Parker OCU filter is supplied including:

- Flow / pressure control valve
- Bypass valve

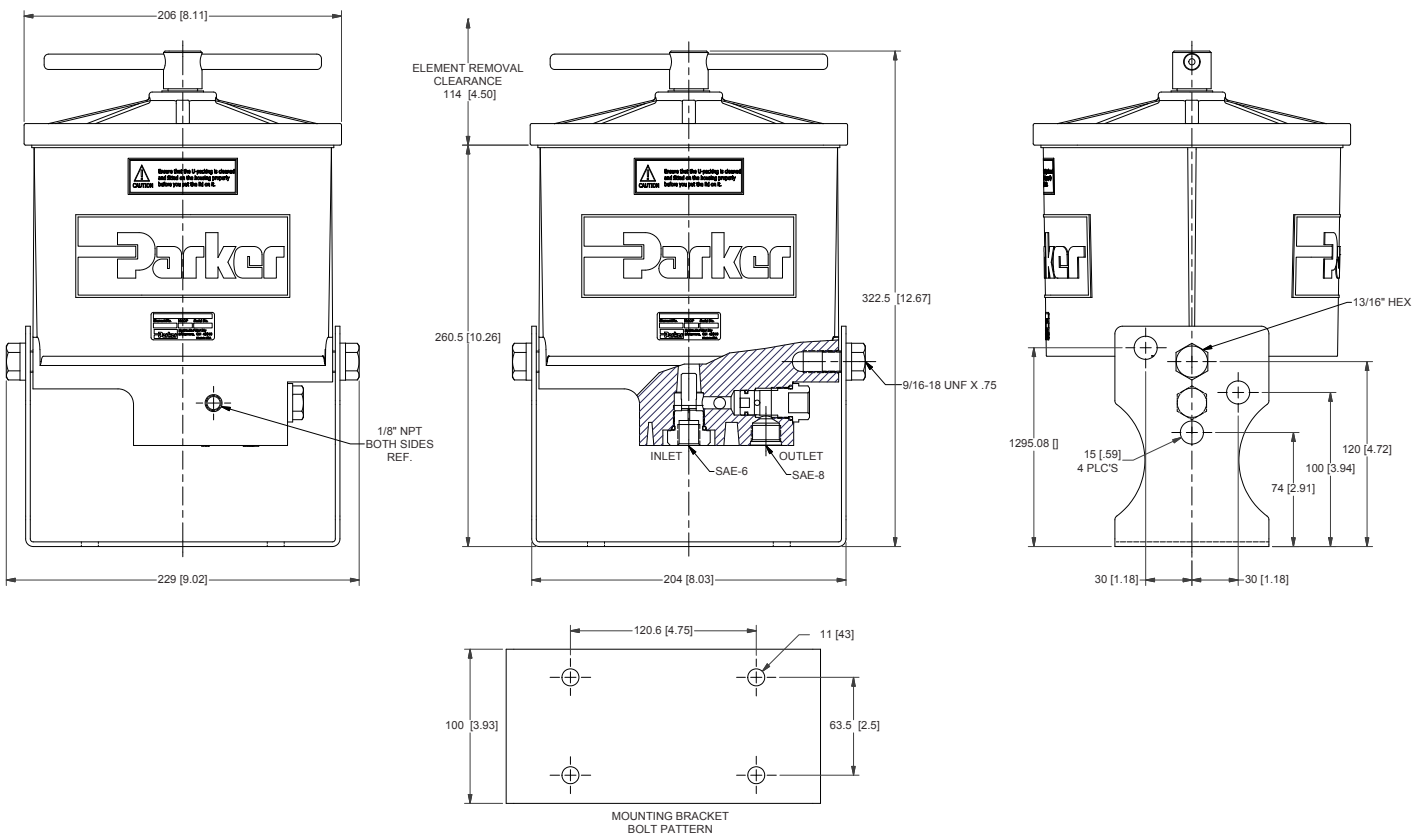

* Dimensions in mm (inch)



OC2 with Pump/Motor

Specifications

Specifications	OC2
Maximum Pressure	12.4 bar (180 PSI)
Port Size (inlet/outlet)	SAE 6/SAE 6
Dimensions	W204 x D206 x H321 mm. (W8.03 x D8.11 x H12.64 in)
Weight	10 kg. (22.1 lbs)
Flow Rate	2 L/min. (0.5 GPM)
Voltage	120VAC or 220VAC

The Parker OCU filter is supplied including:

- Flow / pressure control valve
- Bypass valve

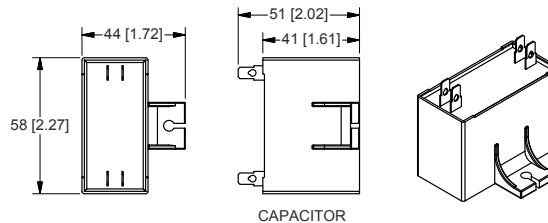
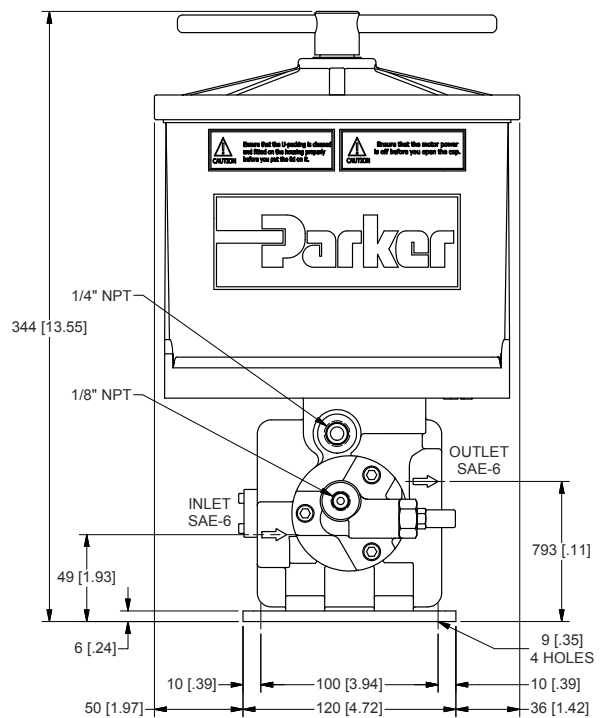
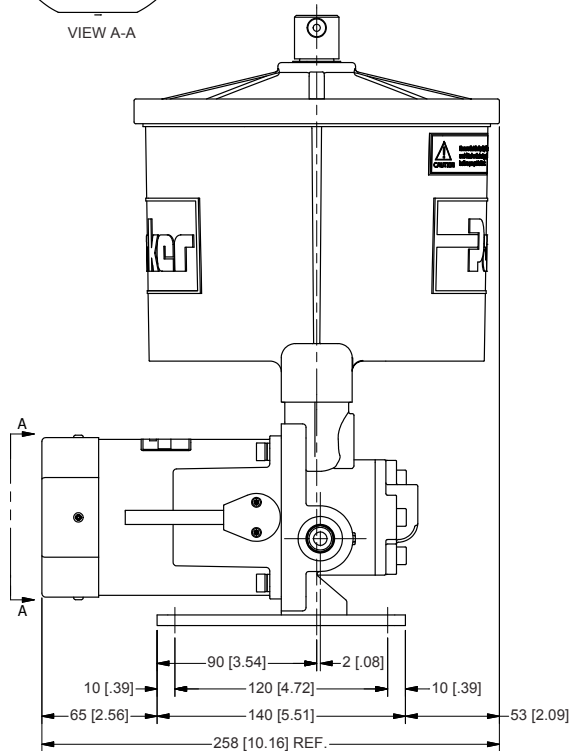
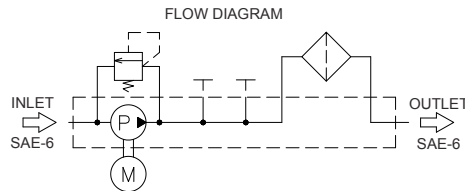
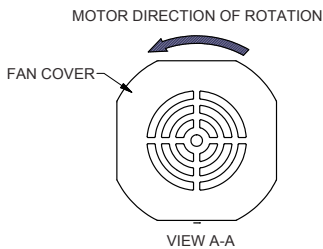

* Dimensions in mm (inch)



Parker Hannifin
Hydraulic Filter Division Europe
FDHB814UK

Oil Conditioning Unit

Parts List

Replacement Parts List	
942673	Seal Service Kit (for OC1)
942683	Seal Service Kit (for OC2)



Replacement Elements	
OC1	
942650	2 micron (green)
942652	10 micron (orange)
OC2	
942654	2 micron filter (green)
942656	10 micron filter (orange)
942682	Water Removal



Oil Conditioning Unit

Ordering Information

Select the desired symbol (in the correct position) to construct a model code.
Example:

BOX 1	BOX 2	BOX 3	BOX 4	BOX 5	BOX 6	BOX 7	BOX 8
OC2	120	10	V	P	L	S06	1

BOX 1: Filter Series ¹	
Symbol	Description
OC1	1.5 L/min. (0.4 GPM)
OC2	2.0 L/min. (0.5 GPM) ¹

BOX 4: Seals	
Symbol	Description
V	Fluorocarbon (FKM)

BOX 7: Ports ⁴	
Symbol	Description
S06	SAE-6 Inlet/Outlet Ports
S08	SAE-6 Inlet Port/SAE-8 Outlet Port ⁴

BOX 2: Filter Model ^{1,2}	
Symbol	Description
120	120VAC/1Ph/60Hz Pump/Motor ²
220	220VAC/1Ph/50/60Hz Pump/Motor ²
X	No Pump/Motor ¹

BOX 5: Indicator	
Symbol	Description
P	Indicator Port Plugged
G	Pressure Gauge
S	Pressure Switch

BOX 8: Options	
Symbol	Description
1	None

BOX 3: Media Code ³	
Symbol	Description
2	2 micron
10	10 micron
WR	Water Removal ³

BOX 6: Bypass	
Symbol	Pressure Setting
L	4.5 bar (65 psid) relief

Notes:

- When selection from Box 1 is "OC2", and selection from Box 2 is "X", "S08" **must** be selected for Box 7.
- "120" and "220" are available **only** when "OC2" is selected in Box 1.
- "WR" available for OC2 **only**.
- "S08" is **only** used when "OC2" is selected in Box 1 and "X" is selected in Box 2.

Parker Worldwide

Europe, Middle East, Africa

AE – United Arab Emirates, Dubai
Tel: +971 4 8127100
parker.me@parker.com

AT – Austria, Wiener Neustadt
Tel: +43 (0)2622 23501-0
parker.austria@parker.com

AT – Eastern Europe, Wiener Neustadt
Tel: +43 (0)2622 23501 900
parker.easteurope@parker.com

AZ – Azerbaijan, Baku
Tel: +994 50 2233 458
parker.azerbaijan@parker.com

BE/LU – Belgium, Nivelles
Tel: +32 (0)67 280 900
parker.belgium@parker.com

BY – Belarus, Minsk
Tel: +375 17 209 9399
parker.belarus@parker.com

CH – Switzerland, Etoy
Tel: +41 (0)21 821 87 00
parker.switzerland@parker.com

CZ – Czech Republic, Klecany
Tel: +420 284 083 111
parker.czechrepublic@parker.com

DE – Germany, Kaarst
Tel: +49 (0)2131 4016 0
parker.germany@parker.com

DK – Denmark, Ballerup
Tel: +45 43 56 04 00
parker.denmark@parker.com

ES – Spain, Madrid
Tel: +34 902 330 001
parker.spain@parker.com

FI – Finland, Vantaa
Tel: +358 (0)20 753 2500
parker.finland@parker.com

FR – France, Contamine s/Arve
Tel: +33 (0)4 50 25 80 25
parker.france@parker.com

GR – Greece, Athens
Tel: +30 210 933 6450
parker.greece@parker.com

HU – Hungary, Budapest
Tel: +36 1 220 4155
parker.hungary@parker.com

IE – Ireland, Dublin
Tel: +353 (0)1 466 6370
parker.ireland@parker.com

IT – Italy, Corsico (MI)
Tel: +39 02 45 19 21
parker.italy@parker.com

KZ – Kazakhstan, Almaty
Tel: +7 7272 505 800
parker.easteurope@parker.com

NL – The Netherlands, Oldenzaal
Tel: +31 (0)541 585 000
parker.nl@parker.com

NO – Norway, Asker
Tel: +47 66 75 34 00
parker.norway@parker.com

PL – Poland, Warsaw
Tel: +48 (0)22 573 24 00
parker.poland@parker.com

PT – Portugal, Leca da Palmeira
Tel: +351 22 999 7360
parker.portugal@parker.com

RO – Romania, Bucharest
Tel: +40 21 252 1382
parker.romania@parker.com

RU – Russia, Moscow
Tel: +7 495 645-2156
parker.russia@parker.com

SE – Sweden, Spånga
Tel: +46 (0)8 59 79 50 00
parker.sweden@parker.com

SK – Slovakia, Banská Bystrica
Tel: +421 484 162 252
parker.slovakia@parker.com

SL – Slovenia, Novo Mesto
Tel: +386 7 337 6650
parker.slovenia@parker.com

TR – Turkey, Istanbul
Tel: +90 216 4997081
parker.turkey@parker.com

UA – Ukraine, Kiev
Tel: +380 44 494 2731
parker.ukraine@parker.com

UK – United Kingdom, Warwick
Tel: +44 (0)1926 317 878
parker.uk@parker.com

ZA – South Africa, Kempton Park
Tel: +27 (0)11 961 0700
parker.southafrica@parker.com

North America

CA – Canada, Milton, Ontario
Tel: +1 905 693 3000

US – USA, Cleveland
Tel: +1 216 896 3000

Asia Pacific

AU – Australia, Castle Hill
Tel: +61 (0)2-9634 7777

CN – China, Shanghai
Tel: +86 21 2899 5000

HK – Hong Kong
Tel: +852 2428 8008

IN – India, Mumbai
Tel: +91 22 6513 7081-85

JP – Japan, Tokyo
Tel: +81 (0)3 6408 3901

KR – South Korea, Seoul
Tel: +82 2 559 0400

MY – Malaysia, Shah Alam
Tel: +60 3 7849 0800

NZ – New Zealand, Mt Wellington
Tel: +64 9 574 1744

SG – Singapore
Tel: +65 6887 6300

TH – Thailand, Bangkok
Tel: +662 186 7000-99

TW – Taiwan, Taipei
Tel: +886 2 2298 8987

South America

AR – Argentina, Buenos Aires
Tel: +54 3327 44 4129

BR – Brazil, Sao Jose dos Campos
Tel: +55 800 727 5374

CL – Chile, Santiago
Tel: +56 2 623 1216

MX – Mexico, Apodaca
Tel: +52 81 8156 6000

European Product Information Centre

Free phone: 00 800 27 27 5374

(from AT, BE, CH, CZ, DE, DK, EE, ES, FI, FR, IE, IL, IS, IT, LU, MT, NL, NO, PL, PT, RU, SE, SK, UK, ZA)

